



# R3A-FG

## Three Section Full Glass Door Refrigerator



R3A-FG  
04/23/19  
Item # 13511

**W x D x H**  
82.5" x 34.5" x 79.5"\*  
\*with 4" casters

Item #: \_\_\_\_\_  
Project: \_\_\_\_\_  
Qty: \_\_\_\_\_  
AIA#: \_\_\_\_\_



## Features

- ▶ **Maximum interior storage capacity with smallest external footprint**
- ▶ **Stainless steel interior with stainless steel exterior front, sides and top**
- ▶ **Unique ducted air distribution system**
  - Refrigerant flow is controlled with thermostatic expansion valve
  - Energy efficient interior LED light
  - Environmentally friendly R290 hydrocarbon refrigerant
- Solid state digital controller with temperature alarms and LED display (Fahrenheit or Celsius)
- Cabinet and doors are insulated with 2-3/8" of CFC free, foamed in place polyurethane
- Glass doors are energy efficient multi pane, argon filled with locks
- Exclusive stepped door design to protect recessed door gasket
- Spring assisted self-closing doors with stay open feature
- Sturdy 8 gauge stainless steel hinge plate with welded hinge pin
- Extruded aluminum flush mount door handle
- Field reversible doors
- Evaporator coils are epoxy electrocoated (E-Coat) to help fight corrosion
- Energy efficient automatic hot gas condensate evaporator
- Top mount refrigeration comes standard with a condenser filter
- Stainless steel shelf supports
- (3) epoxy coated wire shelves are standard per section
- Standard with 4" casters (four with brakes)
- Stackable (two units high) to conserve warehouse floor space
- 10 ft. cord and plug



### Dimensions / Capacity

	Three Section R3A-FG
<b>Interior Storage Capacity</b> (CF) (AHAM)	79.03 ft <sup>3</sup>
<b>Overall Width x Depth</b>	82.5" x 34.5"
<b>Height</b> (including 4" casters)	79.5"
<b>Door Opening Width x Height</b>	21.75" x 57"
<b>Depth with Door Open at 90°</b>	59.25"
<b>Adjustable Shelves</b>	9
<b>Shelf Dimensions (W x D)</b>	21.25" x 26"
<b>Adjustable Center Shelf</b>	6
<b>Center Shelf Dimensions (WxD)</b>	22.9" x 6"
<b>Crated Shipping Weight</b>	826 lbs
<b>Crated Length x Width x Height</b>	86" x 37.5" x 81"

### Electrical / Refrigeration

	Three Section R3A-FG
<b>Voltage</b>	115/60/1
<b>HACR Breaker</b>	15.0 Amps
<b>Electrical Connection</b> (NEMA)	5-15P Ⓢ
<b>Voltage Range</b>	104-126
<b>Ambient Temp. Range</b>	45° to 100°F
<b>Control Setpoint Range</b>	31° to 52°F
<b>Amperage</b>	8.6
<b>Energy Consumption</b> (kWh/day) @ASHRAE	6.5
<b>Heat Rejection</b> (BTU/Hr.) @NSF	1255
<b>Approx. Nominal Compres.</b> BTU/HR (HP)	770(1/4HP)
<b>Refrigerant / Charge Amount</b> (oz)	R290 / (4.6 oz)

### Options

- Additional epoxy shelves
- Foot pedal door opener
- Stainless steel shelves
- Tray/Pan slides

### Warranty

\* 3 Year - parts and Labor on entire machine.  
5 Year - Parts on Compressor  
Valid in United States, Canada, Puerto Rico and U.S. Territories. Contact factory for warranty in other countries.

*Hoshizaki reserves the right to change specifications without notice.*



# R3A-FG

## Three Section Full Glass Door Refrigerator



R3A-FG  
04/23/19  
Item # 13511

FRONT VIEW

SIDE VIEW

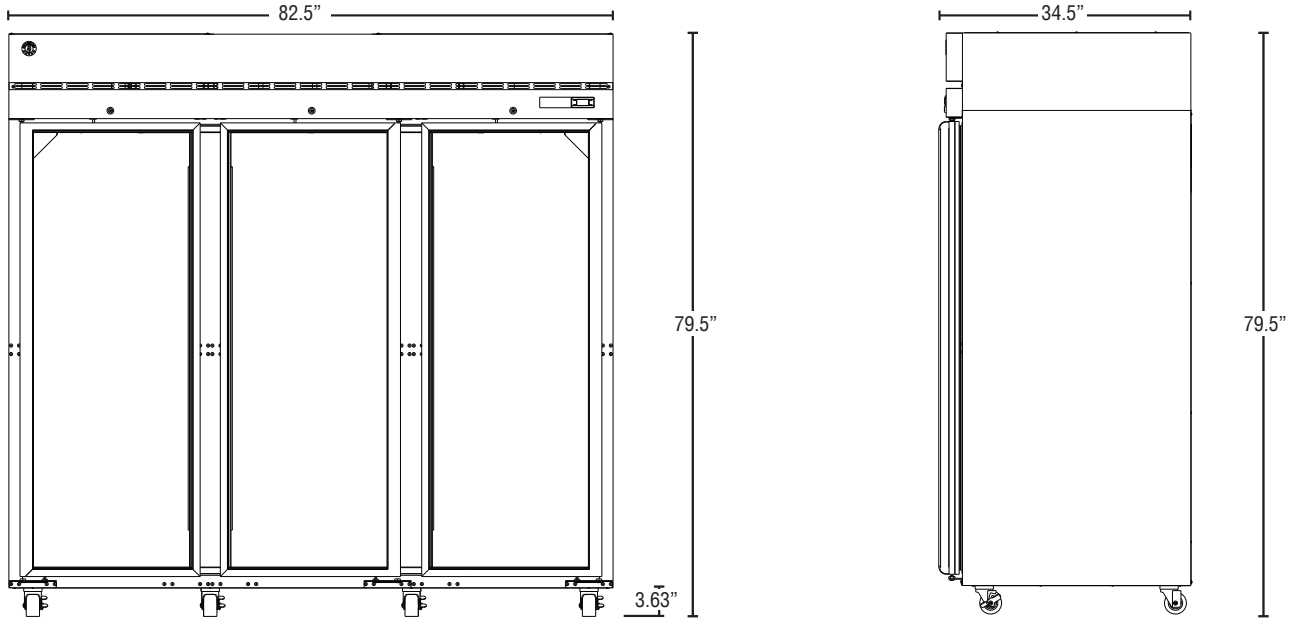

PLAN VIEW

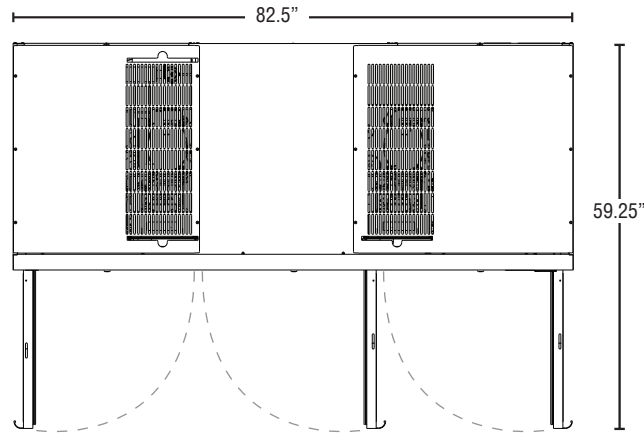

### Cabinet Construction

The exterior cabinet front, sides, and top are constructed of high quality stainless steel. The exterior back, and bottom are constructed of coated steel. The cabinet interior is constructed of stainless steel with a unique ducted air flow system. Three (3) heavy duty epoxy coated shelves per section are standard. Mounted on stainless steel pilasters shelves are adjustable in 1" increments. Cabinet walls and doors are insulated with 2-3/8" of environmentally friendly, CFC free, foamed in place polyurethane. Three (3) four foot interior LED lights are automatically activated when doors are opened. 4" polyolefin, casters (four with brakes) are standard.

### Door Construction

Glass doors are constructed of high grade silver anodized aluminum with a full length chrome handle. Door glass is energy efficient multi pane, argon filled with locks. The door hinges are all metal and include an adjustable torsion spring closure that will not wear out like traditional cam-lift hinges. Hinge plates are constructed of heavy duty stainless steel. Doors stay open at 90° and are self-closing at 75°. Snap-in magnetic door gaskets are durable and easily removed for cleaning. Door hinging is field reversible.

### Refrigeration System

The high efficiency refrigeration system is self-contained with an epoxy electrocoated (E-Coat) evaporator for extended life. Top mounted refrigeration system is easily accessible for service and includes a condenser filter with easy access from the top of the unit. The refrigeration system components are assembled on a high density expanded polypropylene platform that is removable from the main unit. A unique ducted air flow system achieves uniform air distribution within the cabinet to eliminate hot spots. Condensate removal is accomplished with a top mounted energy efficient non-electric evaporation system. A thermostatic expansion valve (TXV) controls the flow of environmentally friendly R290 refrigerant through the evaporator. Refrigeration system utilizes a time initiated off cycle defrost to eliminate any ice on the evaporator coil. Solid state digital controls monitor the operation and performance of the refrigeration system. The controls also provide visual high and low temperature and high and low voltage alarms. A LED display shows the cabinet temperature and is adjustable to Fahrenheit or Celsius. 115 volt units are equipped with a ten foot cord and plug (20.0 amps or less).